

MD85MG-CAN/UAVCAN

#1-01573, #1-01645

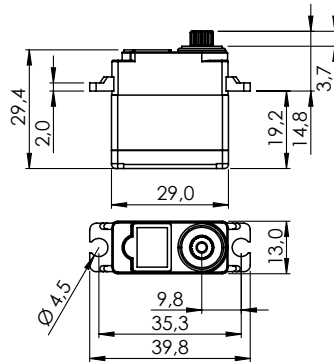

General Specification		MD85MG-CAN/UAVCAN		
Control System	CAN BUS			
	Protocol (Mode)	Standard 2.0A	Extended 2.0B	UAVCAN
	Baud-Rate	10kbps ~ 1Mbps		
	Sample-Point	50% or 87.5%		
	Available SERVO ID	1 ~ 254		1 ~ 127
	Available Node ID	1 ~ 2047	1 ~ 536870911	1 ~ 127
Input Signal Range	0 ~ 5V			
Connector Type	Hitec 4P			
Position Sensor Type	Contactless Encoder			
Motor Type	Cored			
Controller (MCU)	32Bit			
Operating Voltage Range	4.8V ~ 6.0V			
Operating Voltage	At 4.8V	At 6.0V		
No Load Speed	353°/s (59RPM)	462°/s (77RPM)		
Stall Torque	3.6kgcm (35.30Ncm)	4.3kgcm (42.17Ncm)		
Idle Current	30mA	30mA		
No Load Running Current	320mA	380mA		
Stall Current	1,500mA	1,800mA		
Deadband Width	4Step	4Step		
Travel	Travel / Command	90° / 4096		
	Servo mode	Left	Center	Right
	Pos Command	+1366	+8192	+15018
	Pos [°]	-150	0	+150
	Turn Mode	Left	Power On	Right
	Pos Command	-16383	0	+16383
	Pos [°]	-359	0	+359
Turn Range	-32760 ~ +32760			
Operating Temperature Range	-20°C ~ +60°C (-4°F ~ +140°F)			
Storage Temperature Range	-30°C ~ +80°C (-31°F ~ +176°F)			
Vibrations at No Load	MIL-STD-810G 514.6C-VII			
Connector Wire Length	300mm			
Connector Wire Gauge	28AWG			
Connector Wire Strand Count	20EA			
Outline Dimensions	29.0 x 13.0 x 30.0mm			
Weight*	22.7g			
Ball Bearing	Single Ball Bearing / MR106			
Case Material	Engineering Plastic			
Gear Material	5 Metal Gears			
Gear Train Backlash	Max 0.5°			
Horn Gear Spline	24T Ø5.76			
Accessories	Mounting Hardware, M-I, M-X, M-O			
Dust & Water Protection class	IP4X			
Revision	Rev. 1.0 / 17.02.2022			
Changelog	-			

*of the servo only w/o horns and accessories