

HSB-9381TH

#1-00074

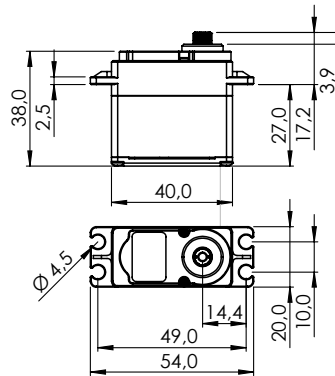

General Specification		HSB-9381TH	
Control System	Pulse Width Modulation (PWM)		
	PWM Range	900µs 1500µs 2100µs	
Connector Type	Hitec 3P (JR 3P compatible)		
Position Sensor Type	Indirect Drive / 4 Slider / 1M Cycle Long Life		
Motor Type	BLDC		
Controller (MCU)	16 Bit Programmable Digital		
Operating Voltage Range	6.0V ~ 7.4V		
Operating Voltage	At 6.0V	At 7.4V	
No Load Speed	353°/s (59RPM)	429°/s (71RPM)	
Stall Torque	34.0kgcm (333.43Ncm)	34.0kgcm (333.43Ncm)	
Idle Current	27mA	27mA	
No Load Running Current	250mA	250mA	
Stall Current	2,700mA	2,100mA	
Deadband Width	1µs	1µs	
Operating Travel	Default	±60°	
	Programmable	±87,5°	
	Multi Turn	n/a	
	Continuous Rotation	n/a	
Operating Temperature Range	-20°C ~ +60°C (-4°F ~ +140°F)		
Storage Temperature Range	-30°C ~ +80°C (-31°F ~ +176°F)		
Vibrations at No Load	-		
Connector Wire Length	300mm		
Connector Wire Gauge	20AWG		
Connector Wire Strand Count	80EA		
Outline Dimensions	40.0 x 20.0 x 38.0mm		
Weight*	79.0g		
Ball Bearing	Dual Ball Bearing / MR106		
Case Material	Rugged Aluminum Alloy		
Gear Material	1 Metal-Plastic & 3 Titanium Alloy Gears		
Gear Train Backlash	Max 0.5°		
Horn Gear Spline	H25T Ø6.0		
Accessories	Mounting Hardware, HD-IM25, HD-LS25, HD-OS25, HS-X25		
Dust & Water Protection class	IP54		
Revision	Rev. 1.0 / 17.02.2022		
Changelog	-		

*of the servo only w/o horns and accessories